

TORQUE DAMPER

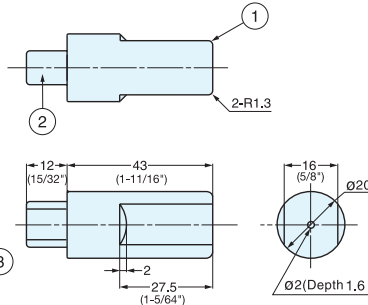

UDH

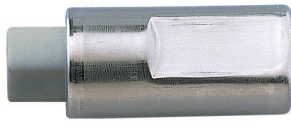

UDH Type

- Keeps lid from slamming shut.
- High torque within compact cartridge.
- Operating temperature: 0°C~40°C (32°F~104°F)

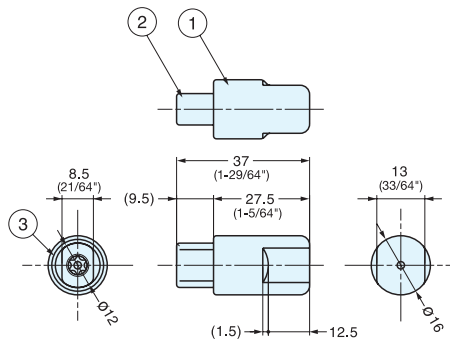
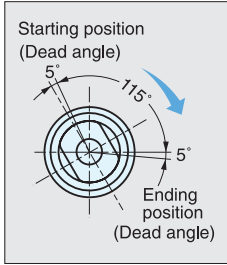

UDH-16 Type



Application

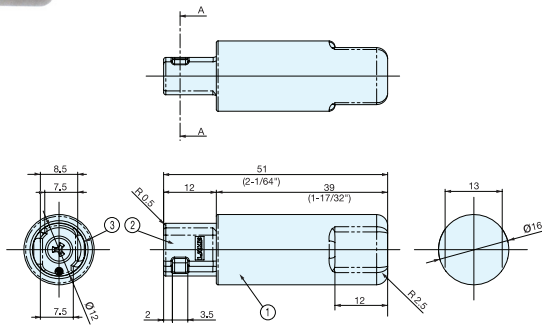
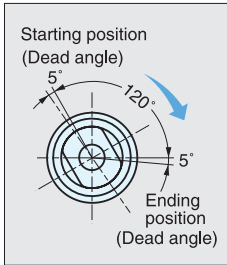

UDH-16N Type

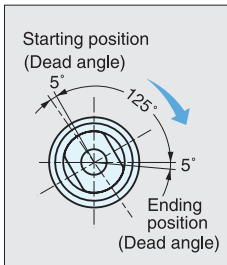

UDH Type

No.	Part Name	Material	Finish/Color
①	Body	304 Stainless Steel	Plain
②	Shaft	PBT Plastic	A-White, B-Grey
③	Cover Ring	304 Stainless Steel	-

UDH-16 Type

No.	Part Name	Material	Finish/Color
①	Body	304 Stainless Steel	Plain
②	Shaft	PBT Plastic	A-White B-Grey
③	Cover Ring		-

UDH-16N Type

No.	Part Name	Material	Finish/Color
①	Body	304 Stainless Steel	Plain
②	Shaft	PBT Plastic	A-White B-Grey
③	Cover Ring	PPS Plastic	-

Item No.	Torque per piece (kgf·cm)	Dampening Direction	Weight (g)	Carton (pcs)		
UDH-AMS	15.0~25.0 (13~21 lbs-in)	Counter Clockwise	38	200		
UDH-BMS		Clockwise				
UDH-AHS	25.0~35.0 (21~30 lbs-in)	Counter Clockwise				
UDH-BHS		Clockwise				
UDH-AGS	35.0~40.0 (30~34 lbs-in)	Counter Clockwise			16	200
UDH-16AMS	10.2~17.3 (8.8~15 lbs-in)	Counter Clockwise				
UDH-16BMS		Clockwise				
UDH-16AHS	17.3~25.5 (15~22 lbs-in)	Counter Clockwise				
UDH-16BHS		Clockwise				
UDH-16N AMS	17.3~24.5 (15~21.2 lbs-in)	Counter Clockwise	20	200		
UDH-16N BMS		Clockwise				
UDH-16N AHS	22.4~30.6 (19.4~26.6 lbs-in)	Counter Clockwise				
UDH-16N BHS		Clockwise				