

TWIN WHEEL CASTER (THREADED BOLT TYPE)

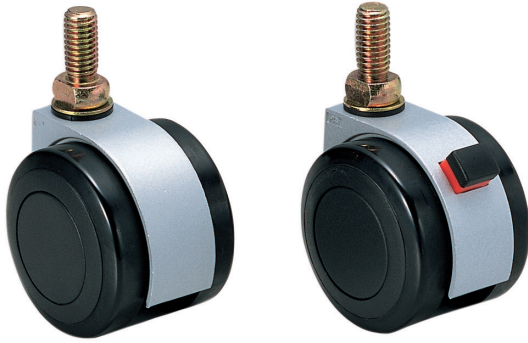

LOAD CAPACITY
70 kg
154 lbs

FAU-55-NS, N



FAU-55-N
(w/o Brake)

FAU-55-NS
(w/ Brake)

- Wheels absorb vibrations with elastomer covering (rubber) for smooth and quiet movement.
- Light & durable aluminum body construction.

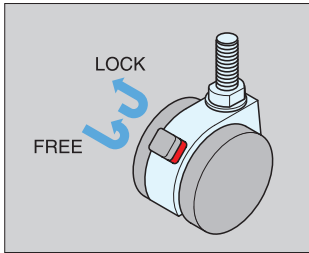
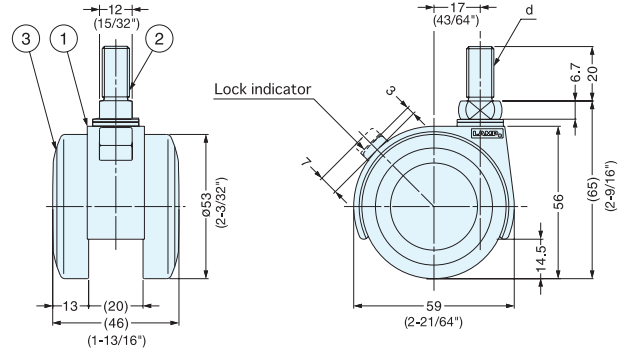

No.	Part Name	Material	Finish
①	Body	Aluminum Alloy	Silver
②	Threaded Bolt	Steel	Yellow Zinc Chromate
③	Wheel	Polyamide/Elastomer	Black

Item No.	d	Load Capacity (kg)	Weight (g)	Box (pcs)	Carton (pcs)
FAU-55-NS -w/Brake-	W3/8-16UNC	70 (154 lbs)	155	4	72
FAU-55-N -w/o Brake-			151		

QXPVÜYRZRQ

TWIN WHEEL CASTER (THREADED BOLT TYPE)



LOAD CAPACITY
50 kg
110 lbs

FPU-55-NS, N

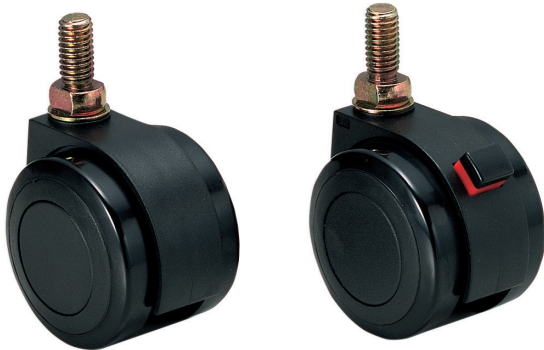

FPU-55-N
(w/o Brake)

FPU-55-NS
(w/ Brake)

- Wheels absorb vibrations with elastomer covering (rubber) for smooth and quiet movement.
- Caster with high quality polyamide body.
- Excellent durability: chemical/weather/wear resistant.

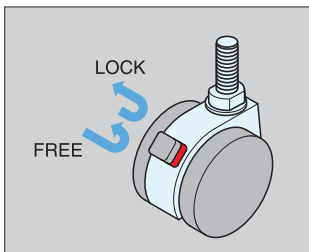
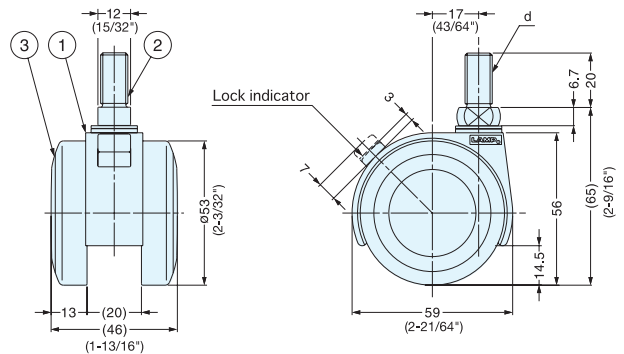

No.	Part Name	Material	Finish
①	Body	Polyamide	Black
②	Threaded Bolt	Steel	Yellow Zinc Chromate
③	Wheel	Polyamide/Elastomer	Black

Item No.	d	Load Capacity (kg)	Weight (g)	Box (pcs)	Carton (pcs)
FPU-55-NS w/Brake	W3/8-16UNC	50 (110 lbs)	128	4	72
FPU-55-N w/o Brake			123		